

MTH PUMPS

T31 Series - 50Hz Metric Edition

- Capacities to 30 LPM
- Heads to 75 Meters
- Low NPSH Requirements
- Horizontal Close Coupled
- Flex Coupled



T31 SERIES

Composite Curves

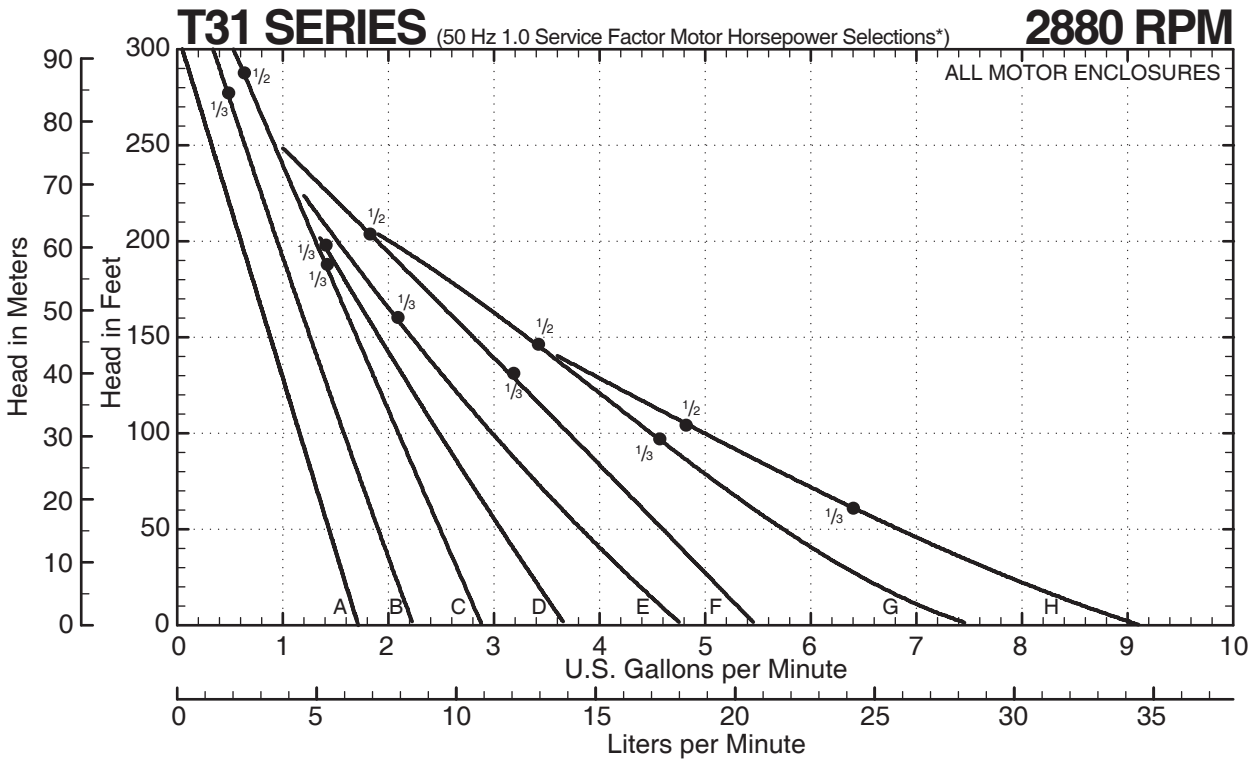

Distributed in the UK by....
Pump Engineering Limited. Unit B1, Riverside Industrial Estate,
 Littlehampton, West Sussex, BN17 5DF, United Kingdom
 Tel: 01903 730900 Fax: 01903 730234
 email: sales@pumpeng.co.uk Web: www.pumpeng.co.uk

* Horsepower data is valid for 1.0 specific gravity fluids only

T31 SERIES PUMPS

T31 SERIES

Performance Curves

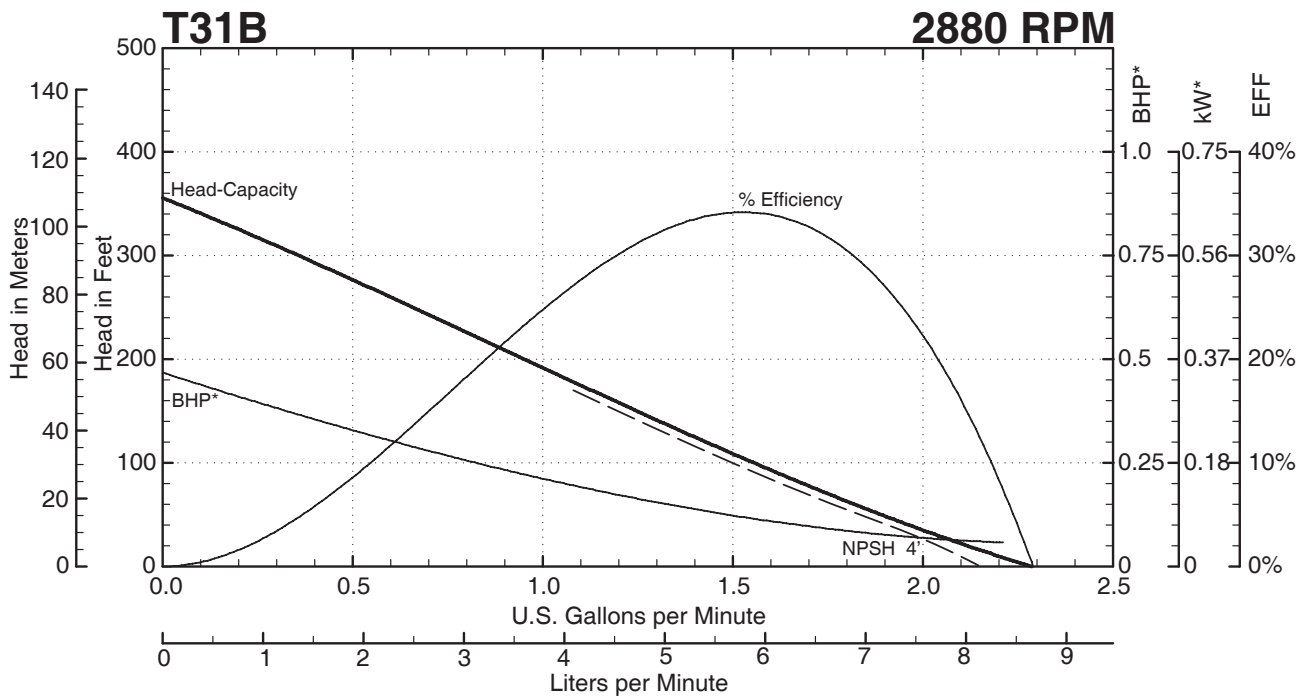
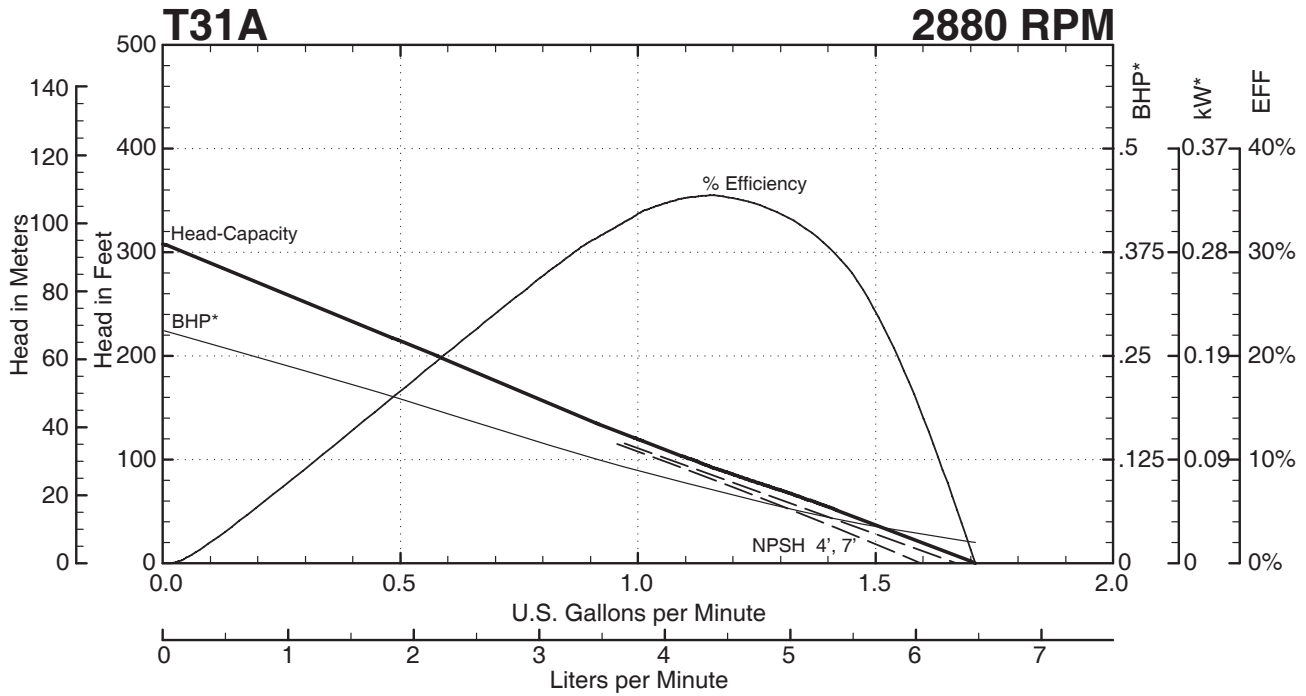

T31 SERIES PUMPS

— — — Indicates altered performance at NPSH Available
 * Horsepower data is valid for 1.0 specific gravity fluids only

T31 SERIES
Performance Curves

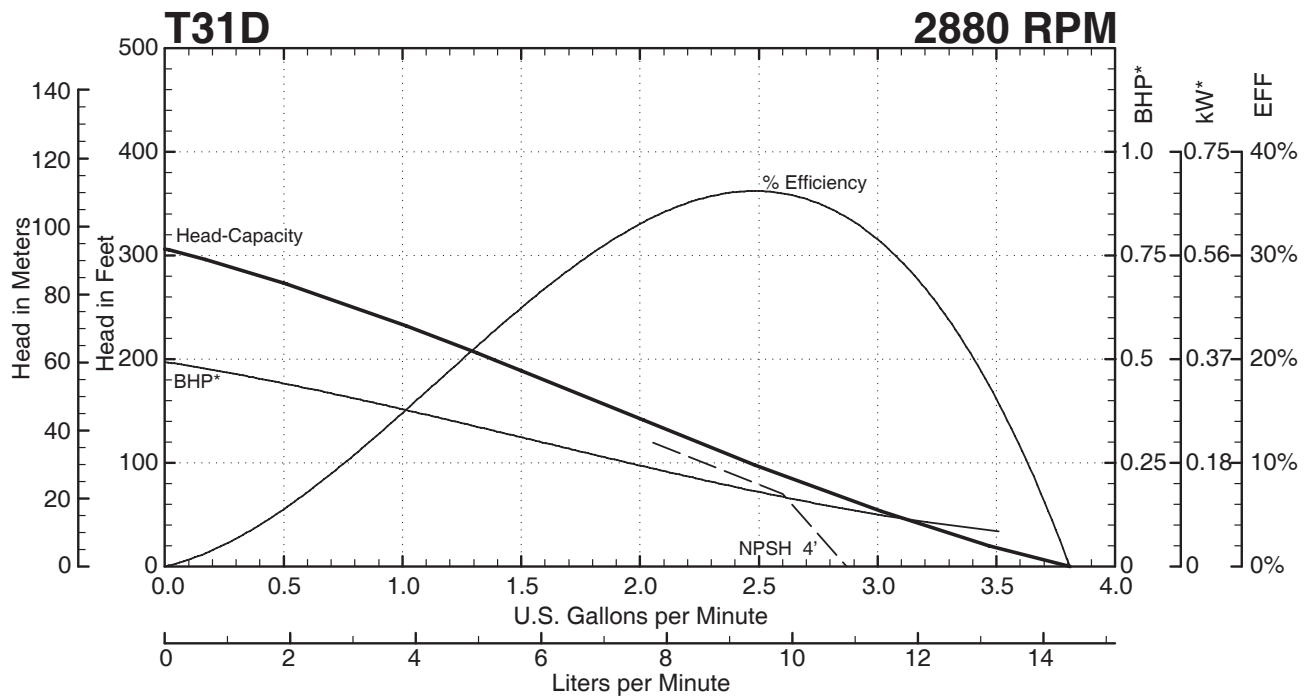
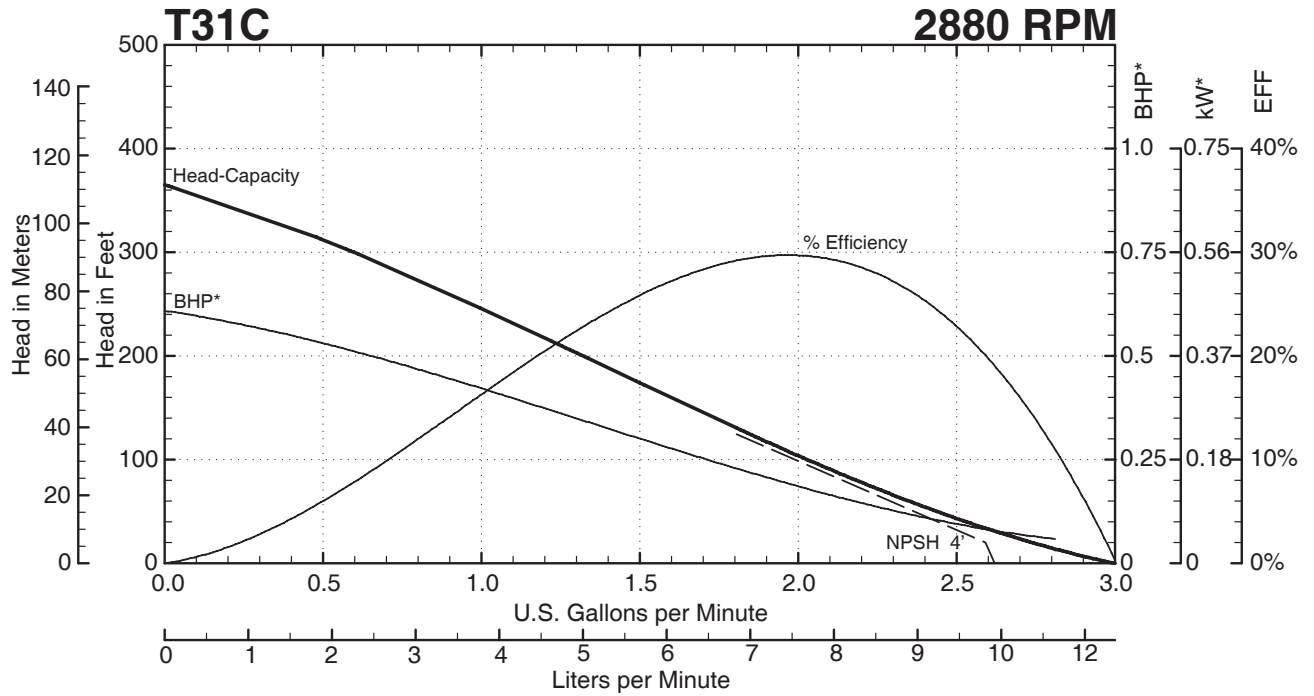

— — — Indicates altered performance at NPSH Available
 * Horsepower data is valid for 1.0 specific gravity fluids only

T31 SERIES PUMPS

T31 SERIES

Performance Curves

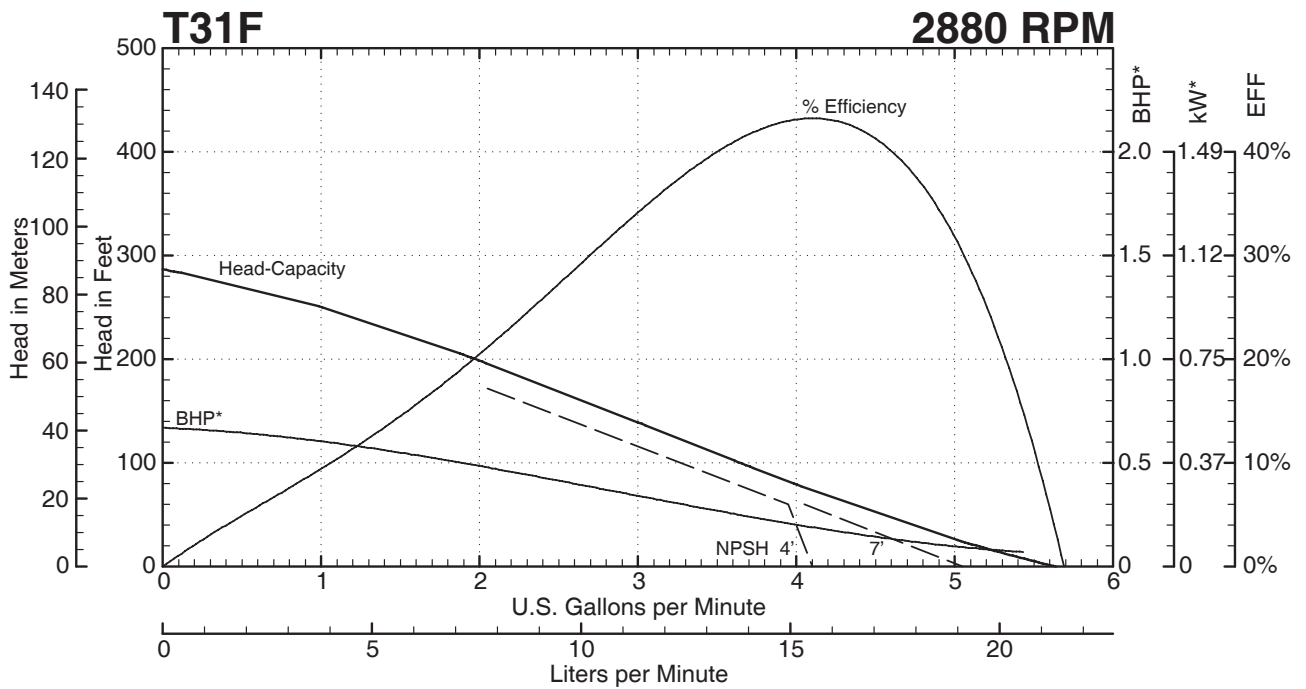
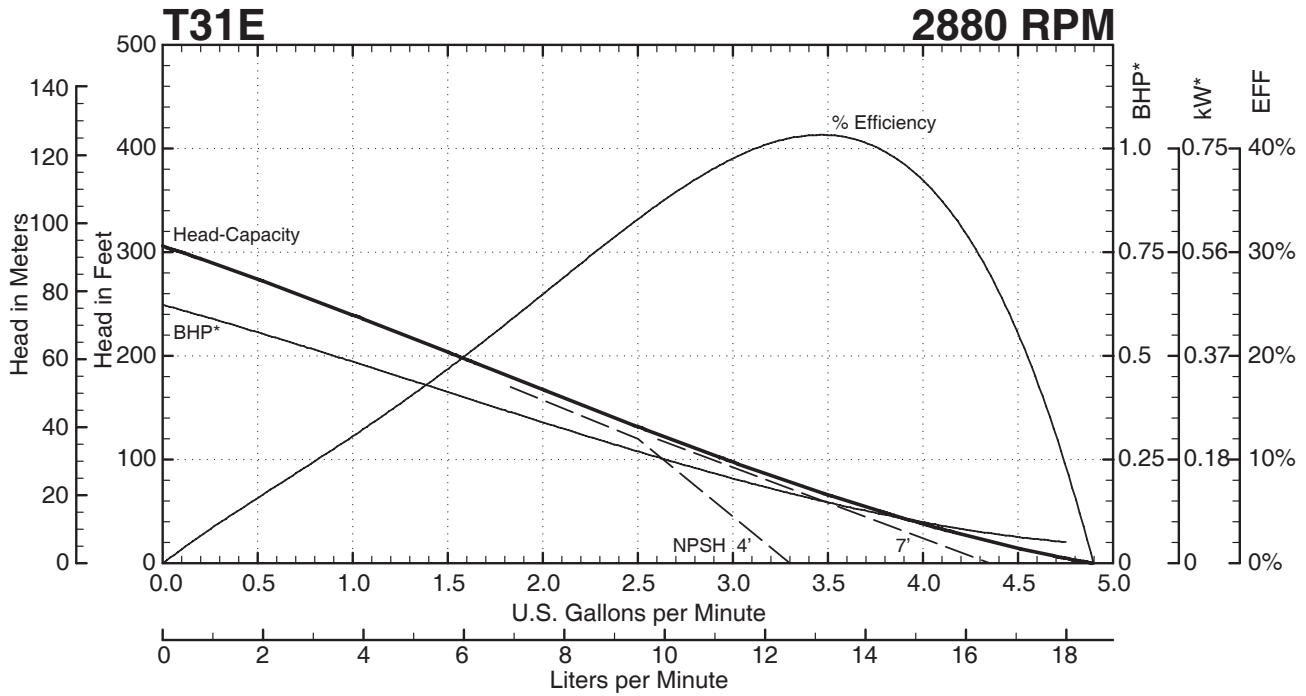

T31 SERIES PUMPS

— — — Indicates altered performance at NPSH Available
 * Horsepower data is valid for 1.0 specific gravity fluids only

T31 SERIES Performance Curves

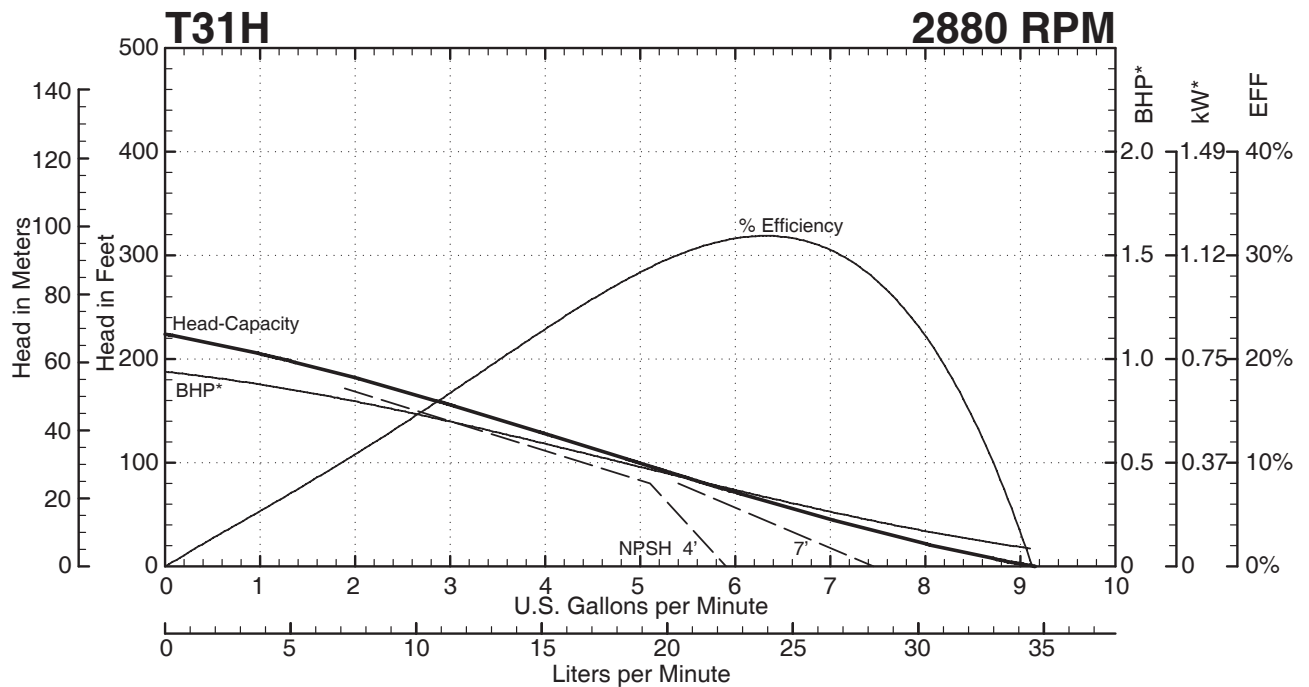
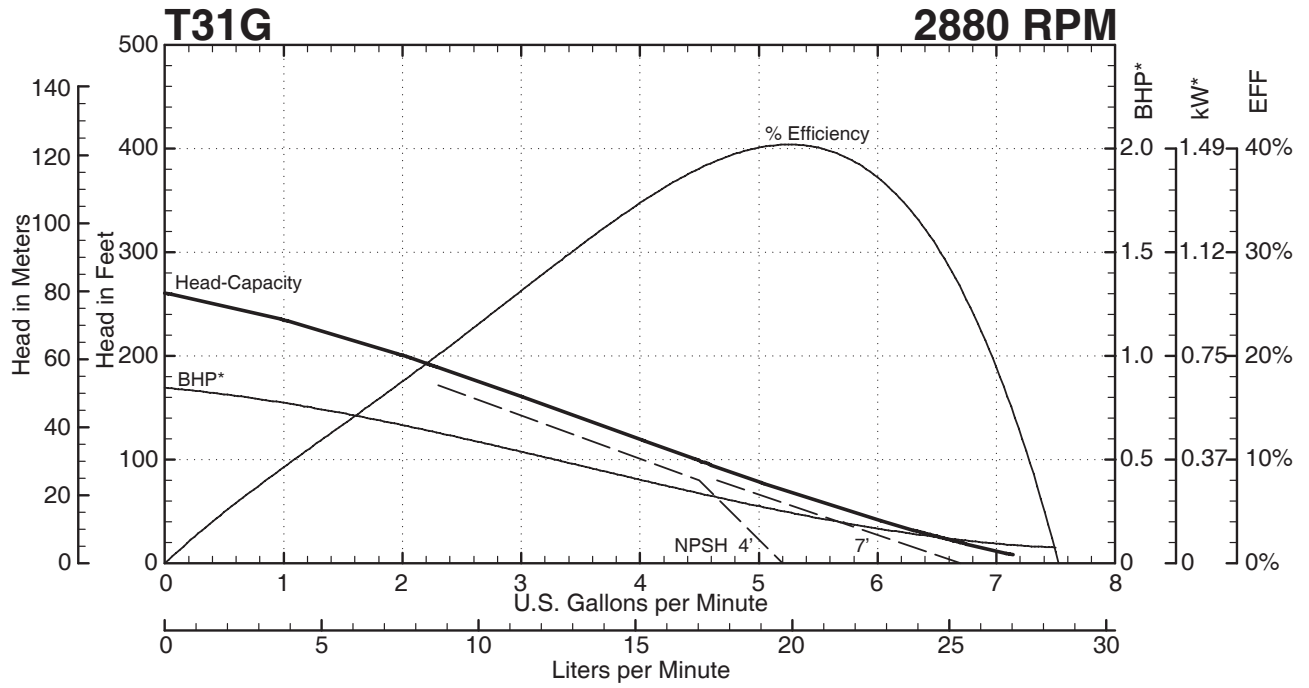

— — — Indicates altered performance at NPSH Available
* Horsepower data is valid for 1.0 specific gravity fluids only

T31 SERIES PUMPS

T31 SERIES

Dimensions

Horizontal Close Coupled

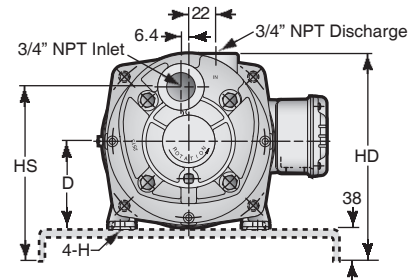
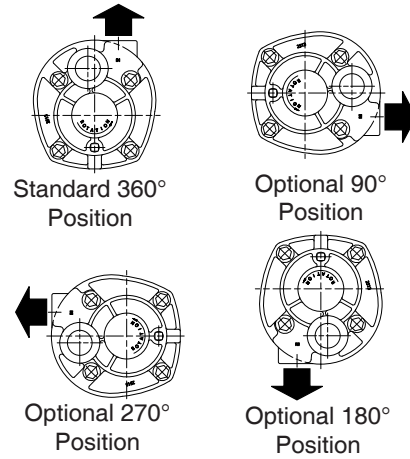
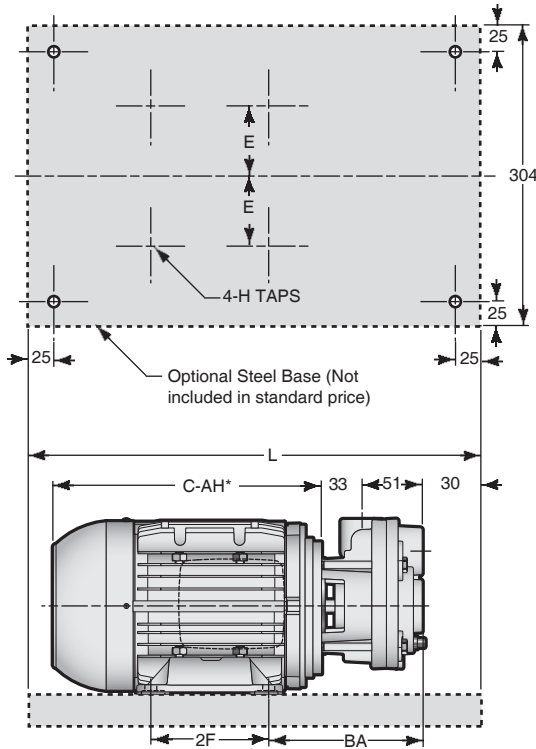

T31 SERIES • THREE PHASE • HORIZONTAL CLOSE COUPLED

HP	FRAME	ENCL	D	E	H	BA	2F	HS	HD	L
1/3 to 1	71	TEF	71.4	55.6	1/4-20	136.5	90.5	154	179.4	457.2
1 1/2	80	TEF	79.4	61.9	3/8-16	139.7	100	161.9	188.9	457.2

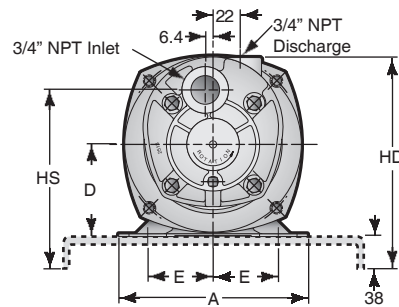
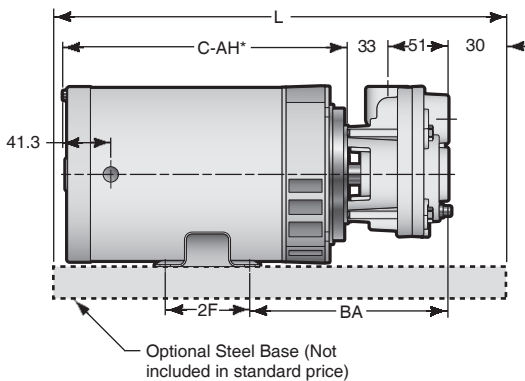

T31 SERIES • SINGLE PHASE • HORIZONTAL CLOSE COUPLED

HP	FRAME	ENCL	A	D	E	H	BA	2F	HS	HD	L
1/3 ~ 1	48	ODP	158.8	76.2	54	5/16-18	160.3	69.9	158.8	185.7	457.2
1 1/2	56	ODP	158.8	88.9	54	5/16-18	161.9	69.9	171.5	198.4	457.2

NOTES

All dimensions in millimeters. May vary ± 6 MM.

Not for construction purposes unless certified.

*See motor dimension (Section Motors) for "C-AH" dimension (varies depending on motor enclosure).

T31 SERIES PUMPS

T31 SERIES

P2 Bearing Frame

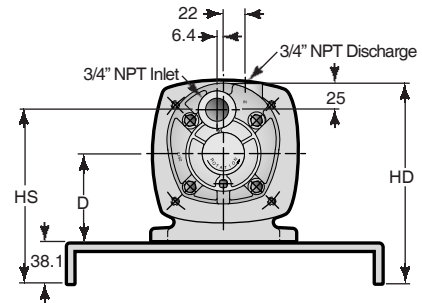
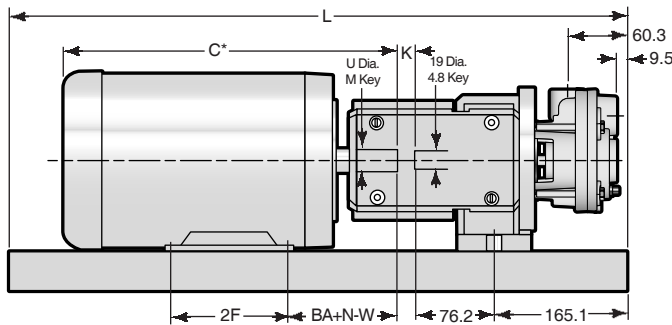
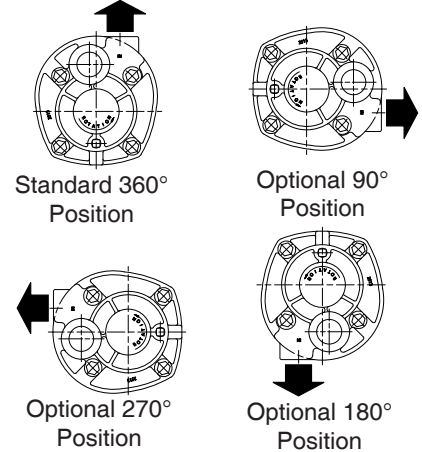
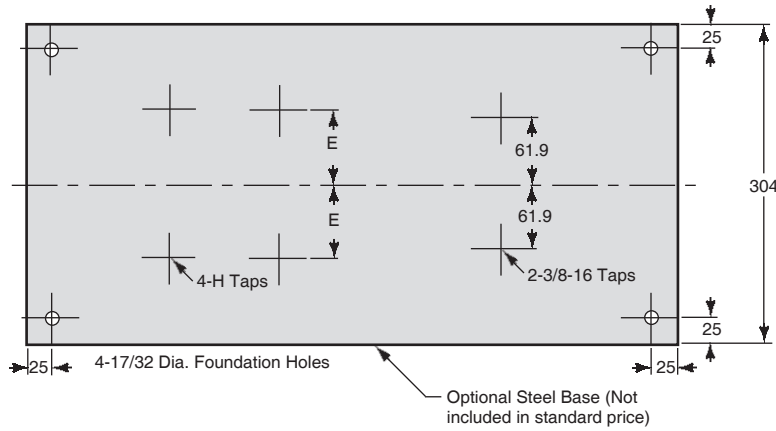

T31 SERIES WITH P2 BEARING FRAME

FRAME	D	U	BA+N+W	2F	E	H	K	HS	HD	L	M
56	88.9	15.9	117.5	76.2	61.9	5/16-18	15.9	158.8	161.9	609.6	4.8



Distributed in the UK by....
Pump Engineering Limited. Unit B1, Riverside Industrial Estate,
 Littlehampton, West Sussex, BN17 5DF, United Kingdom
 Tel: 01903 730900 Fax: 01903 730234
 email: sales@pumpeng.co.uk Web: www.pumpeng.co.uk

NOTES

All dimensions in millimeters. May vary ± 6 MM.
 Not for construction purposes unless certified.
 *See motor dimension (Section Motors) for "C" dimension
 (varies depending on motor enclosure).

T31 SERIES PUMPS